







ASSEMBLY INSTRUCTIONS

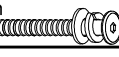

MODEL : SS02003

- IMPORTANT NOTE :**
- * PLACE ALL WOODEN PARTS ON A CLEAN AND SMOOTH SURFACE SUCH AS A RUG OR CARPET TO AVOID THE PARTS FROM BEING SCRATCHED.
 - * BEFORE YOU BEGIN, KINDLY FOLLOW THE ASSEMBLY INSTRUCTIONS STEP BY STEP.
 - * DO NOT TIGHTEN ALL SCREWS UNTIL THE CHAIR IS FULLY SET-UP.

HARDWARE LIST			PART LIST		
A	JCBC M6 x 30mm + S/W M6 + F/W M6 x 13mm 	4PCS	1	RIGHT SIDE FRAME	1PC
B	JCBC M6 x 50mm + S/W M6 + F/W M6 x 13mm 	2PCS	2	LEFT SIDE FRAME	1PC
C	JCBC M6 x 55mm + S/W M6 + F/W M6 x 13mm 	2PCS	3	FRONT STRETCHER	1PC
D	ALLEN KEY M4 	1PC	4	BACK STRETCHER	1PC
E	L BRACKET 	4PCS	5	TOP REST	1PC
F	PH SCREW M4 x 12mm 	8PCS	6	CUSHION SEAT	1PC
G	WOOD DOWEL M8 x 25mm 	2PCS			

CAUTIONS :

- (1) **DO NOT FULLY-TIGHTEN THE NUT OR NUT BOLTS INITIALLY UNTIL ALL NUTS OR BOLT IS READY ASSEMBLED.**
- (TO AVOID CAUSING DAMAGES TO THE THREAD, DO NOT OVER-TIGHTEN THE NUTS OR BOLTS.)
- (2) **KEEP ALL HARDWARE PART OUT OF REACH OF CHILDREN.**

E	L BRACKET 	4PCS
F	PH SCREW M4 x 12mm 	8PCS
G	WOOD DOWEL M8 x 25mm 	2PCS

STEP 2

**ATTENTION:
DO NOT FULLY
TIGHTEN YET**

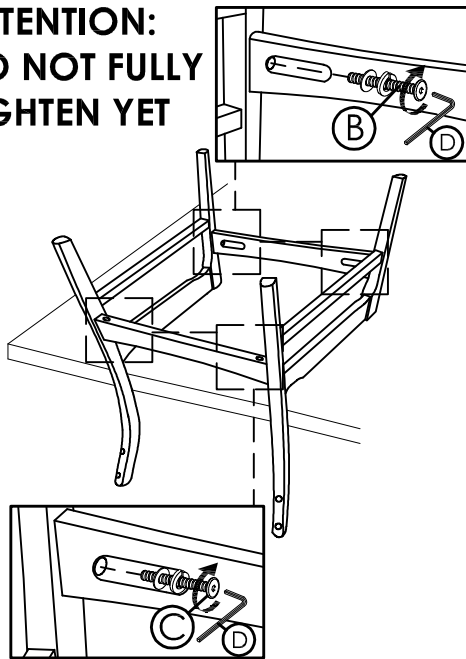

STEP 3

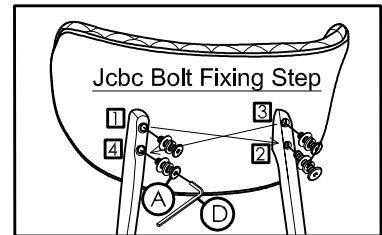

**ATTENTION:
FULLY TIGHTEN
THE BOLT**

STEP 1

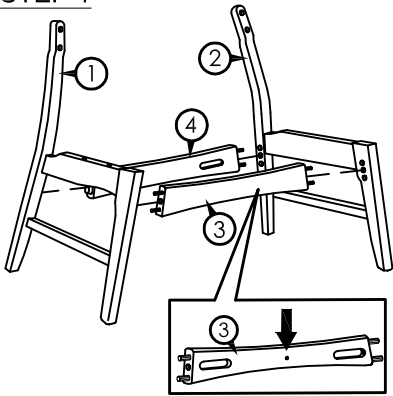

Front Stretcher has a small hole for identification.

STEP 4

**ATTENTION:
PLEASE FULLY
TIGHTEN THE
BOLT NOW**

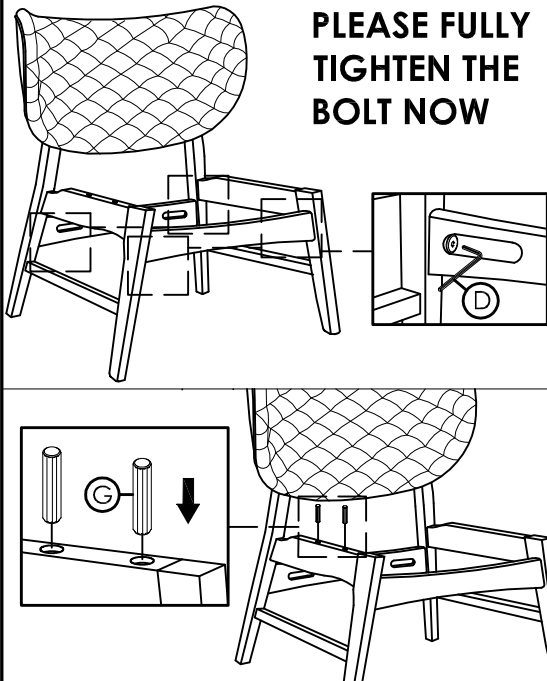

STEP 5

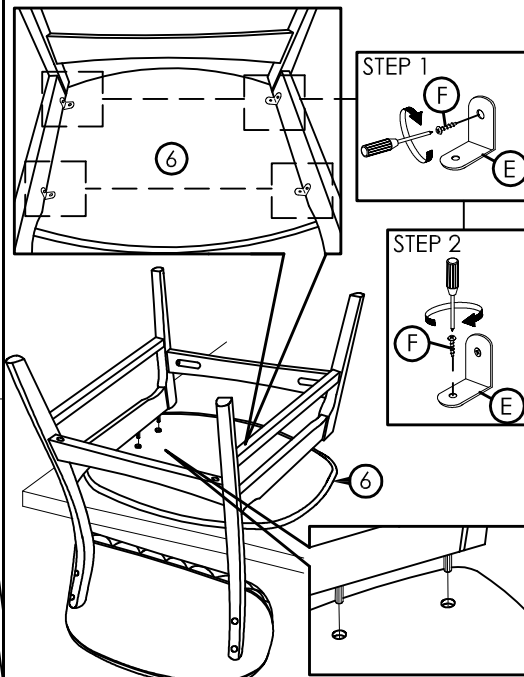

STEP 6



COMPLETED
LOUNGE CHAIR ASSEMBLY.